

Reinforcing Fabric

For Use With *Mapelastic AquaDefense*, *Mapelastic WaterStop* and *Mapelastic Turbo*



DESCRIPTION

MAPEI's *Reinforcing Fabric* is a strong, absorbent, flexible, alkali-resistant, polyester reinforcing fabric for optional use with MAPEI's *Mapelastic® AquaDefense*, *Mapelastic WaterStop* and *Mapelastic Turbo* membranes when installed under ceramic tile or stone on residential and commercial interior applications.

Reinforcing Fabric is ideal for use over substrate areas such as cracks, coves, corners and areas around drains when used with *Mapelastic AquaDefense*, *Mapelastic WaterStop* and *Mapelastic Turbo*. *Reinforcing Fabric* provides a durable, reliable barrier to water migration into adjacent areas. It can easily be cut to size with scissors or a razor knife, and it has excellent compatibility with all MAPEI cement- or epoxy-based grouts and mortars.

FEATURES AND BENEFITS

- Compatible with *Mapelastic AquaDefense*, *Mapelastic WaterStop* and *Mapelastic Turbo* waterproofing and *Mapeband™* accessories – to address a wide variety of installations
- Reduces total installation time by quickly absorbing *Mapelastic AquaDefense*, *Mapelastic WaterStop* and *Mapelastic Turbo*
- Durable and flexible; lays flat, making it easy to install
- Fast to install; easy to cut with scissors or razor knife

WHERE TO USE

Reinforcing Fabric is optional for use when installing *Mapelastic AquaDefense*, *Mapelastic WaterStop* and *Mapelastic Turbo* membranes. See the Technical Data Sheets (TDSs) of these membranes for specific uses.

LIMITATIONS

- For specific limitations, see the TDS for *Mapelastic AquaDefense*, *Mapelastic WaterStop* or *Mapelastic Turbo*.

SUITABLE SUBSTRATES

- For suitable substrates, see the TDS for *Mapelastic AquaDefense*, *Mapelastic WaterStop* or *Mapelastic Turbo*.

Consult MAPEI's Technical Services Department for installation recommendations regarding substrates and conditions not listed.

SURFACE PREPARATION

- Substrates must be smooth, structurally sound and free of any substance that could prevent adhesion.
- Do not use chemical means (acid etching or stripping) to prepare approved substrates. Use mechanical methods only.
- To remove any bond-inhibiting materials, concrete substrates should be mechanically cleaned and prepared by diamond-cup grinding or other engineer-approved methods to obtain the International Concrete Repair Institute (ICRI) concrete surface profile (CSP) of #2. When concrete requires more mechanical preparation, the profile will typically increase. In such cases, the surface can be made smooth by applying coats of MAPEI's *Planipatch*®.
- For other important surface preparation instructions, see individual TDSs for waterproofing products. For other details, see the "Surface preparation requirements" reference guide in the Tile & Stone Installation Systems section of MAPEI's Website.

PRODUCT APPLICATION

For specific application instructions, see the TDS for *Mapelastic AquaDefense*, *Mapelastic WaterStop* or *Mapelastic Turbo*.

EXPANSION AND CONTROL JOINTS

1. Do not cover any substrate expansion joint or control joints with mortar or tiles. Provide for expansion and control joints where specified per TCNA Method EJ-171 or TTMAC Detail 301MJ.
2. If waterproofing integrity is required in expansion and control joints, provide per the drawing below. MAPEI's *Reinforcing Fabric* or *Mapeband* cove roll can be bonded to both sides of the joint and filled with an appropriate joint sealant or an expansion molding system.
3. Protect tilework with metal strips (edge metal) along both edges of structural building expansion joints.
4. When necessary, cut tiles along both edges of the expansion joints. Do not allow tile or mortar to overlap the joints.
5. Install the specified compressible bead and sealant into all expansion and control joints.

Installation with Mapeband:

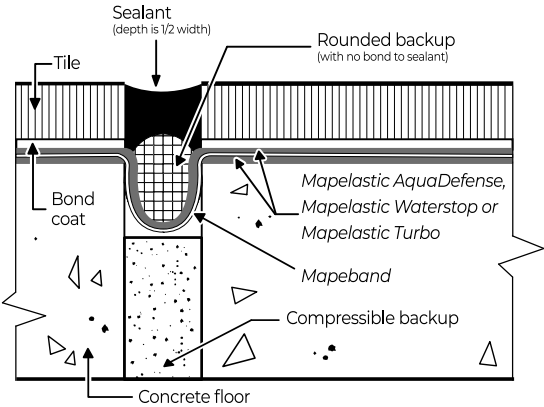

Installation with MAPEI's Reinforcing Fabric:

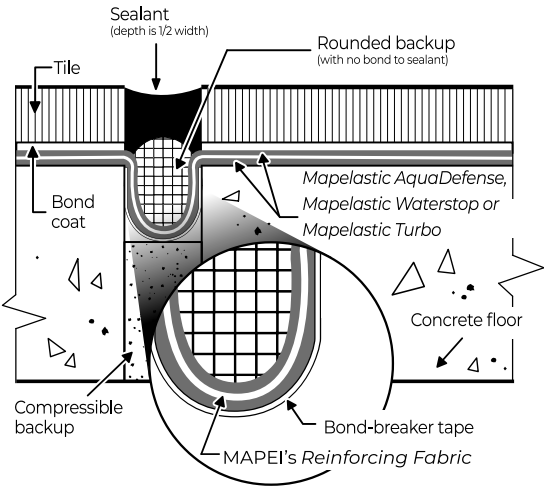

Product Performance Properties

Laboratory Tests	Results
Fabric weight – ASTM D3776	2.06 U.S. oz. per sq. yd. (70 g per m ²)
Grab tensile strength (MD/TD) – ASTM D5034	57.3/52.8 lbf (255/235 N)
Grab tensile elongation (MD/TD) – ASTM D5034	50%/55%
Trapezoidal tear TD – ASTM D1117	24.7 lbf (110 N)
Thickness – ASTM D1117	13.6 mils (0.35 mm)
Air permeability – ASTM D737	670 CFM (18.9 cu. meter/minute)
Mullen burst – ASTM D3786	82.5 psi (402.8 kg-force/m ²)

Shelf Life and Product Characteristics

Color	White
Shelf life	5 years when stored in original, unopened container
Storage	Store in cool, dry place.
Application temperature range	See TDSs for individual products.

Packaging and Coverage

Size*	Coverage
Cove roll: 6" x 75 ft. (15 cm x 22.9 m) – 8 rolls per box	37.5 sq. ft. (3.48 m ²)
Roll: 38" x 75 ft. (0.97 m x 22.9 m)	237.5 sq. ft. (22.1 m ²)

* Rolls can be purchased by the full box only.

ADDITIONAL INFORMATION

Refer to the Safety Data Sheet (SDS) for specific data related to health and safety as well as product handling.

For information on MAPEI's commitment to sustainability and transparency, as well as how MAPEI products may contribute to green building standards and certification systems, contact sustainability_USA@mapei.com (USA) or sustainability-durabilite@mapei.com (Canada).

WARNING

The test results shown in the TECHNICAL DATA table were obtained in compliance with test methods and curing cycles, if applicable, defined in the industry standards referenced on the Technical Data Sheet. Please note that the use of test procedures or methods other than those indicated in the table could lead to different values and that, in such cases, any liability of our company is excluded.

LEGAL NOTICE

The contents of this Technical Data Sheet ("TDS") may be copied into another project-related document, but the resulting document shall not supplement nor replace requirements per the TDS in effect at the time of the MAPEI product installation. For the most up-to-date TDS and warranty information, please visit our website at www.mapei.com. **ANY ALTERATIONS TO THE WORDING OR REQUIREMENTS CONTAINED IN OR DERIVED FROM THIS TDS SHALL VOID ALL RELATED MAPEI WARRANTIES.**

Before using, the user must determine the suitability of our products for the intended use, and the user alone assumes all risks and liability. **ANY CLAIM SHALL BE DEEMED WAIVED UNLESS MADE IN WRITING TO US WITHIN FIFTEEN (15) DAYS FROM DATE IT WAS, OR REASONABLY SHOULD HAVE BEEN, DISCOVERED.**

CONTACT INFORMATION

MAPEI Headquarters of North America

1144 East Newport Center Drive
Deerfield Beach, Florida 33442
1-888-US-MAPEI (1-888-876-2734) / (954) 246-8888

Technical Services

U.S. and Puerto Rico:
Flooring: 1-800-992-6273
Concrete and heavy construction: 1-888-365-0614
Canada:
1-800-361-9309

Customer Service

1-800-42-MAPEI (1-800-426-2734)

Edition Date: February 18, 2025 MK 3000218 (24-3189)

For the most current product data and BEST-BACKEDSM warranty information,
visit www.mapei.com.

All Rights Reserved. © 2025 MAPEI Corporation.

